

NOTE:

1. See the following sheets for Sections A-A through C-C, steel rail layouts, and other details.
2. Use weathering steel for all structural steel and fastener hardware.

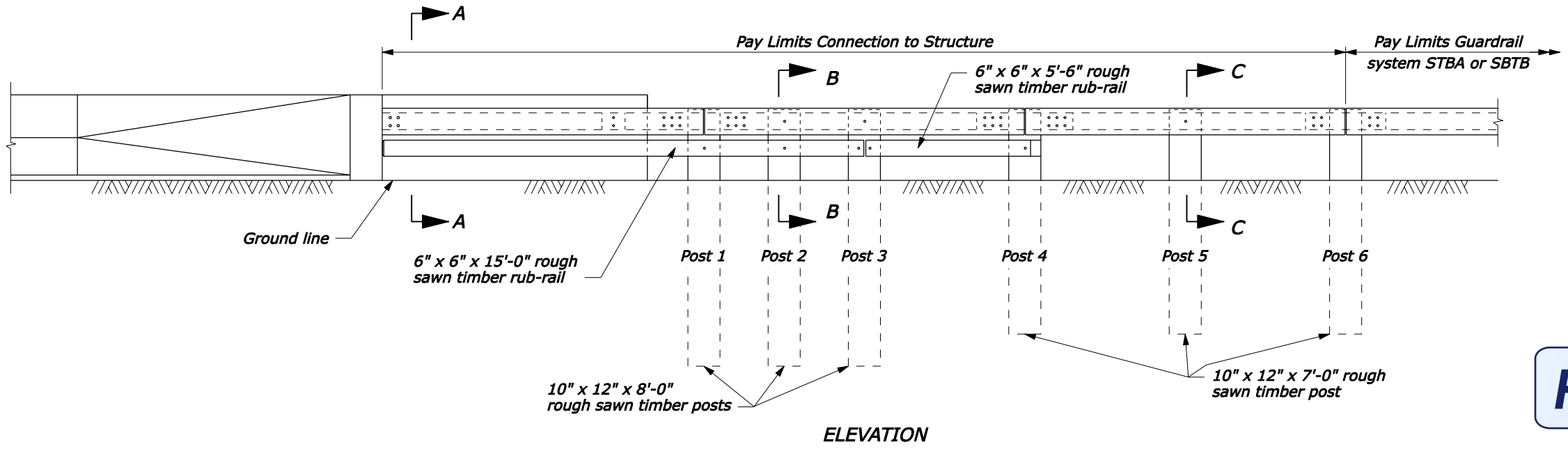

FOR COMMENT

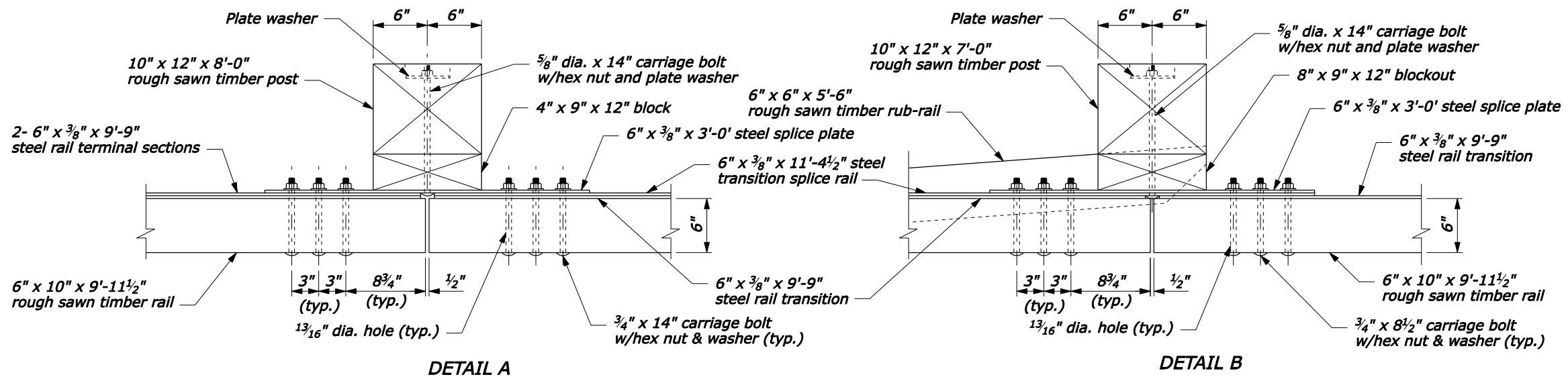

POST CONNECTION

NO SCALE

U.S. DEPARTMENT OF TRANSPORTATION
 FEDERAL HIGHWAY ADMINISTRATION
 FEDERAL LANDS HIGHWAY

U.S. CUSTOMARY STANDARD
**STEEL-BACKED TIMBER
 GUARDRAIL CONNECTION TO
 CURVED BACK STRUCTURE**
 Sheet 1 of 3

| | |
|----------------------------------|----------|
| STANDARD APPROVED FOR USE 1/1994 | STANDARD |
| REVISED: 4/1994 | 617-66 |
| DRAFT: 4/2005 | |

F:\StanDraw\Draw\18\181766.dgn [US Customary] 14-Apr-2005 02:18 PM

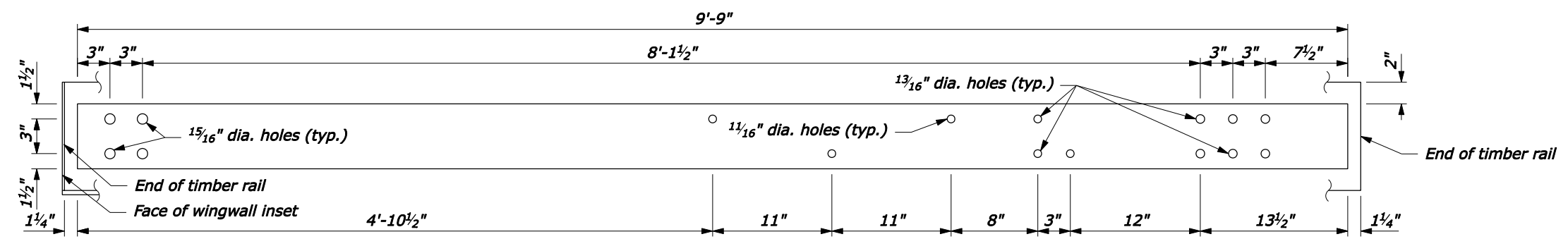

TERMINAL SECTION RAIL
6" x 3/8" x 9'-9"

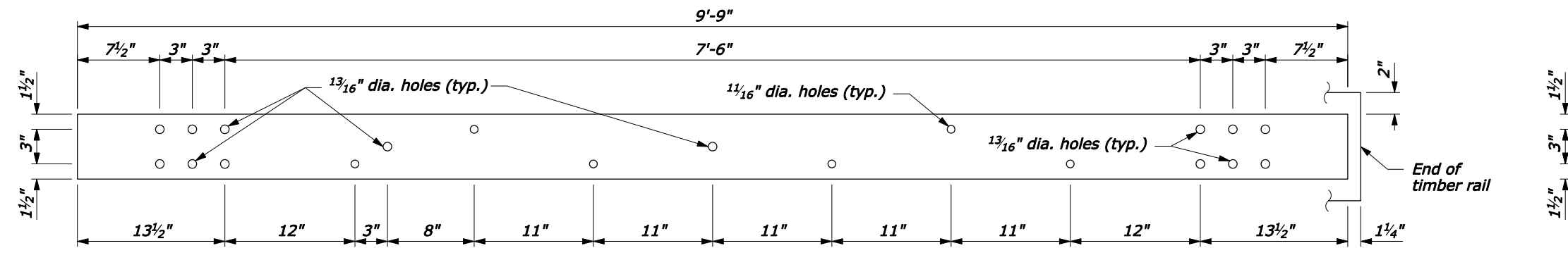

TRANSITION RAIL
6" x 3/8" x 9'-9"

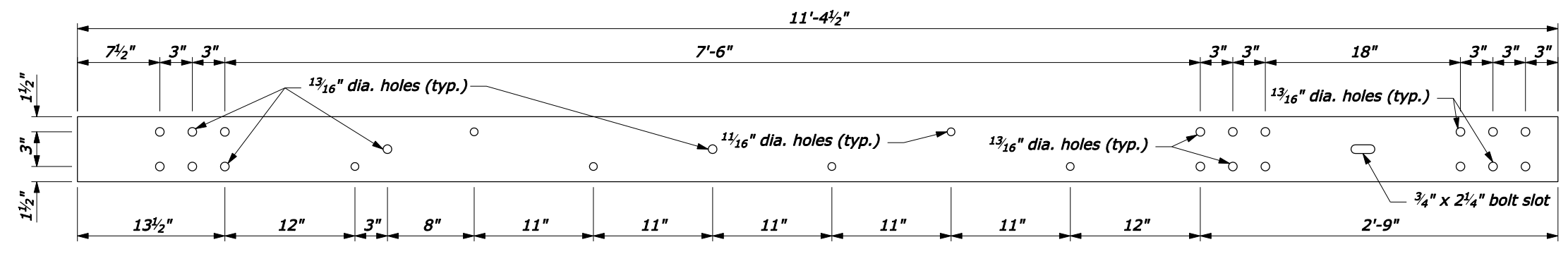

TRANSITION SPLICE RAIL
6" x 3/8" x 11'-4 1/2"

NOTE:
1. Pre-drill 5/8-inch holes in timber rail and 3/8-inch holes in the wood spacer block for the 5/8-inch lag screws.

FOR COMMENT

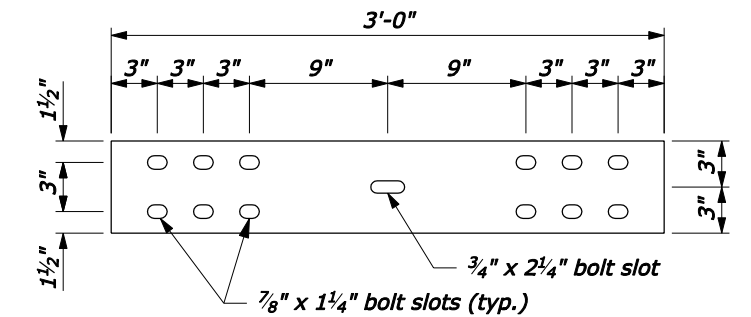

SPLICE PLATE
6" x 3/8" x 3'-0"

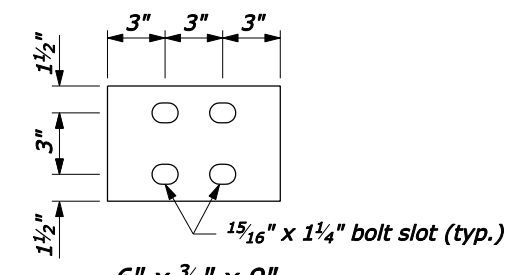

6" x 3/8" x 9"

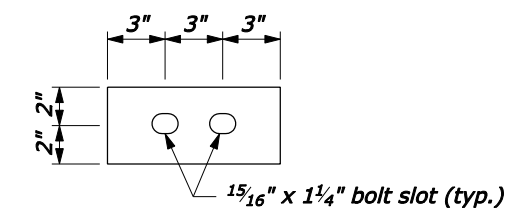

4" x 3/8" x 9"

BEARING PLATE DETAILS

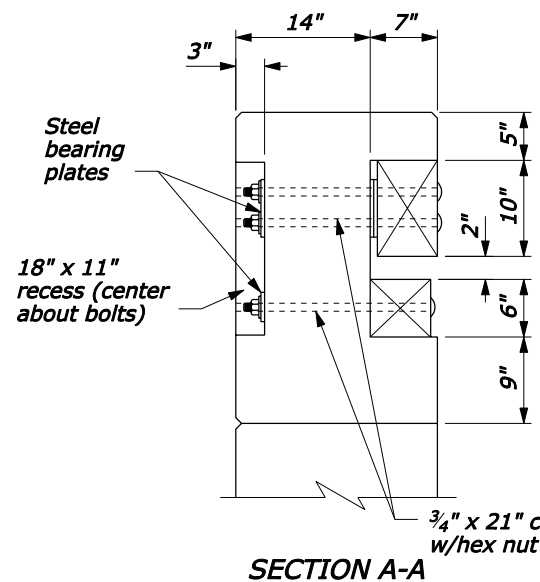

SECTION A-A

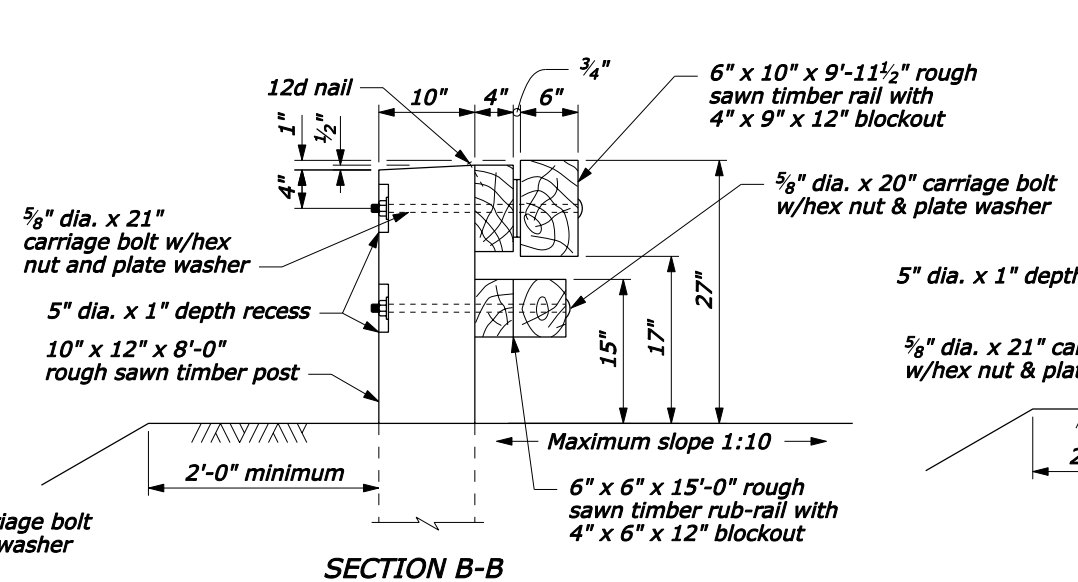

SECTION B-B

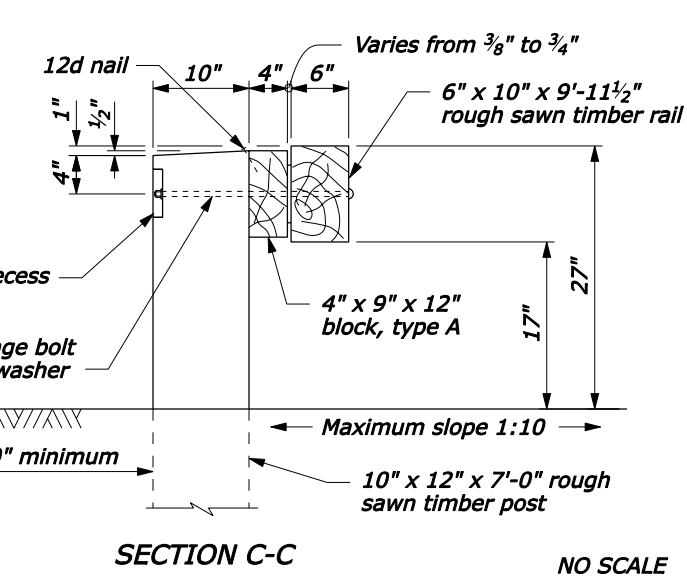

SECTION C-C

NO SCALE

U.S. DEPARTMENT OF TRANSPORTATION
FEDERAL HIGHWAY ADMINISTRATION
FEDERAL LANDS HIGHWAY

U.S. CUSTOMARY STANDARD
**STEEL-BACKED TIMBER
GUARDRAIL CONNECTION TO
CURVED BACK STRUCTURE**
Sheet 2 of 3

| | |
|----------------------------------|----------|
| STANDARD APPROVED FOR USE 1/1994 | STANDARD |
| REVISED: 4/1994 | 617-66 |
| DRAFT: 4/2005 | |

F:\StanDraw\Draw\181766.dgn [US Customary] 14-Apr-2005 02:18 PM

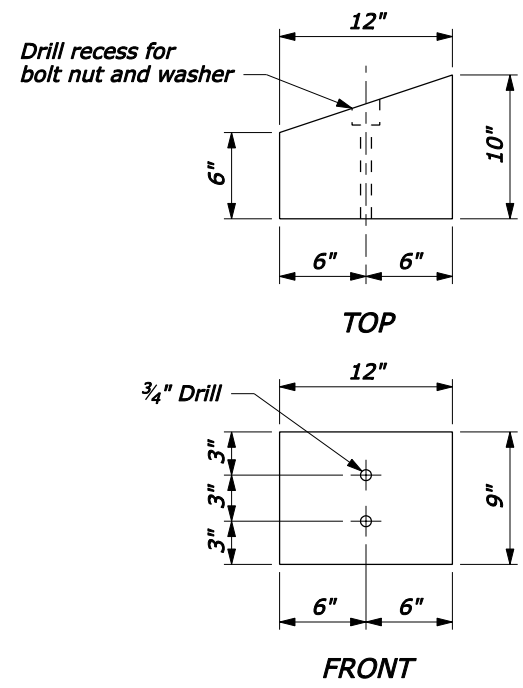

SPACER BLOCK FOR RAIL

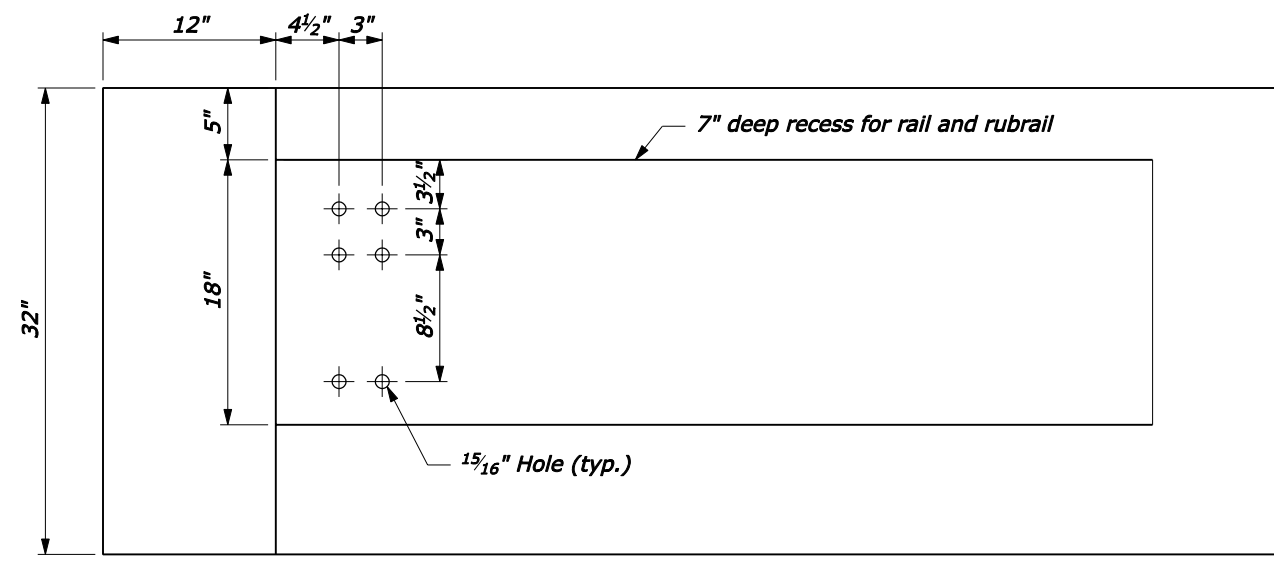

PARAPET ATTACHMENT DETAIL

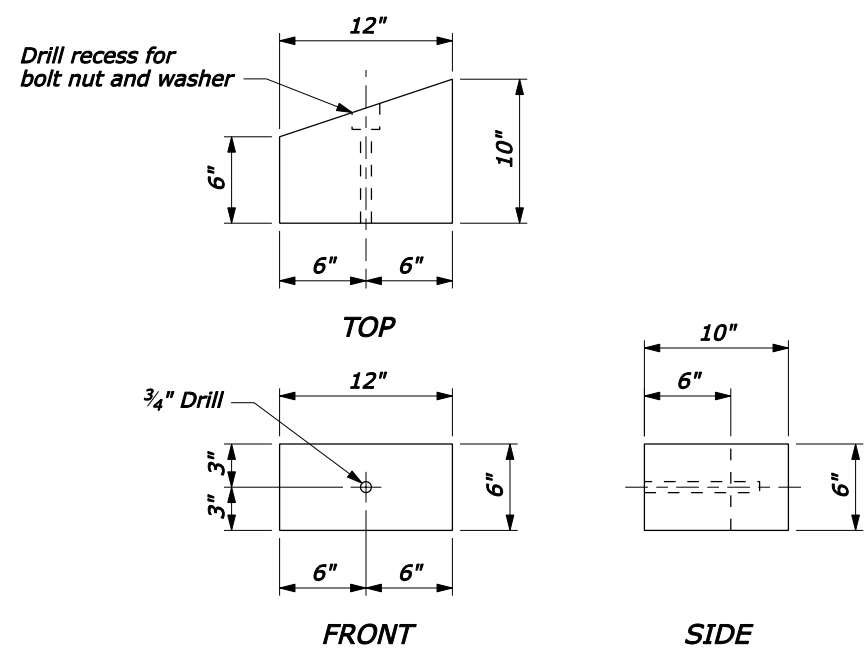

SPACER BLOCK FOR RUB-RAIL

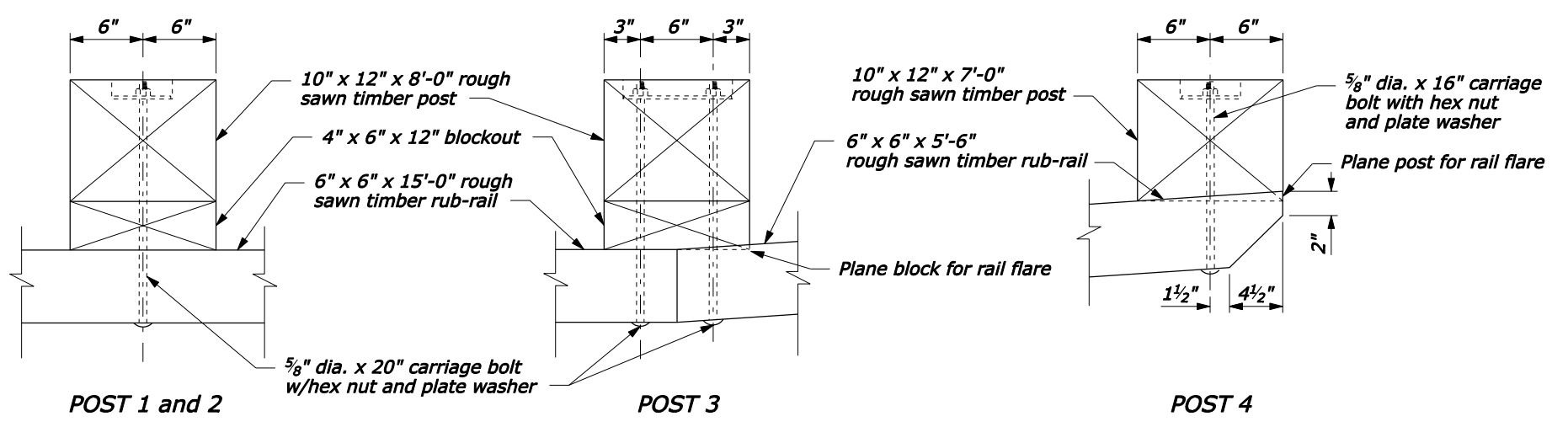

RUB-RAIL CONNECTIONS

FOR COMMENT

NO SCALE

| | |
|---|--------------------|
| U.S. DEPARTMENT OF TRANSPORTATION FEDERAL HIGHWAY ADMINISTRATION FEDERAL LANDS HIGHWAY | |
| U.S. CUSTOMARY STANDARD STEEL-BACKED TIMBER GUARDRAIL CONNECTION TO CURVED BACK STRUCTURE Sheet 3 of 3 | |
| STANDARD APPROVED FOR USE 1/1994 REVISED: 4/1994 DRAFT: 4/2005 | STANDARD 617-66 |

F:\StandDraw\Draft\181766.dgn [US Customary] 14-Apr-2005 02:18 PM